

**DIPLOMA EXAMINATION IN ENGINEERING/TECHNOLOGY/
MANAGEMENT/COMMERCIAL PRACTICE, NOVEMBER – 2022**

ENGINEERING GRAPHICS

[Maximum Marks: 75]

[Time: 3 Hours]

- [Note: 1. A2 size drawing sheet to be supplied
2. Missing data if any, suitably assumed
3. Sketches are accompanied
4. All dimensions as per BIS
5. All drawings should be in first angle projections.]

PART-A

- I. Answer all the following questions in one word or one sentence or sketch. Each question Carries 'one' mark.**

(5 x 1 = 5 Marks)

		Module Outcome	Cognitive level
1.	Write any two applications of continuous thick lines.	M1.02	U
2.	In the case of parabola, the eccentricity is.....	M1.04	U
3.	Define a projector.	M2.01	U
4.	What is an isometric projection?	M3.01	U
5.	Define CADD.	M4.04	R

PART-B

- II. Answer any five questions from the following. Each question carries 'eight' marks.**

(5 x 8 = 40 Marks)

		Module Outcome	Cognitive level
1.	Draw a regular pentagon having 50mm side.	M1.04	U
2.	Construct a regular octagon of 30mm side length.	M1.04	U
3.	Draw an ellipse by eccentricity method. Given eccentricity as $\frac{4}{7}$ and one focus is at a distance of 40mm from the directrix.	M1.04	U
4.	Draw a parabola by rectangular method, given the sides of rectangle as 120mm and 50mm.	M1.04	U
5.	Draw the projections of the following points on a common reference line: A is 30mm above H.P and 20mm in front of V.P B is 30mm below H.P and 30mm behind V.P C is 35mm above H.P and 15mm behind V.P	M2.02	U
6.	Draw the projections of a line PQ, 70mm long, inclined 60° to H.P, parallel to V.P and 20mm in front of V.P	M2.03	A

7.	The top view of a line parallel to V.P and inclined 40° to H.P is 60mm. One end of line is 15mm above H.P and 30mm in front of V.P. Draw the projections of the line and determine the true length.	M2.03	A
----	--	-------	---

PART-C

Answer any two questions from the following. Each question carries 'fifteen' marks

(2 x 15 = 30 Marks)

Module Outcome Cognitive level

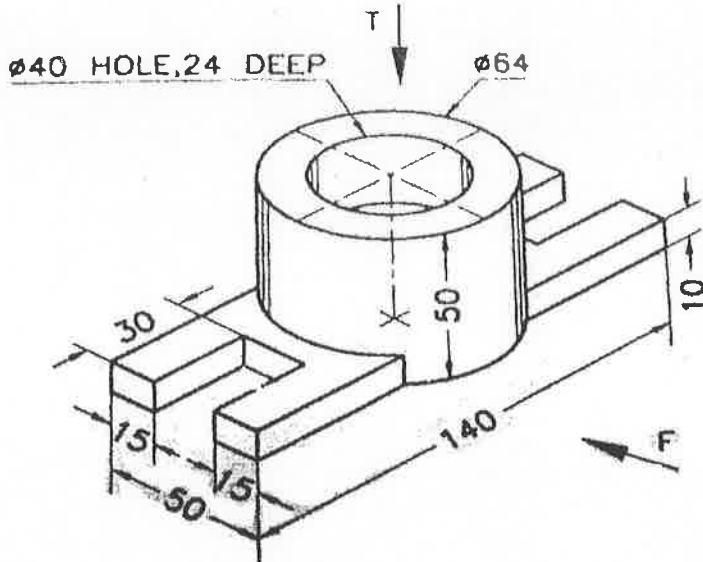
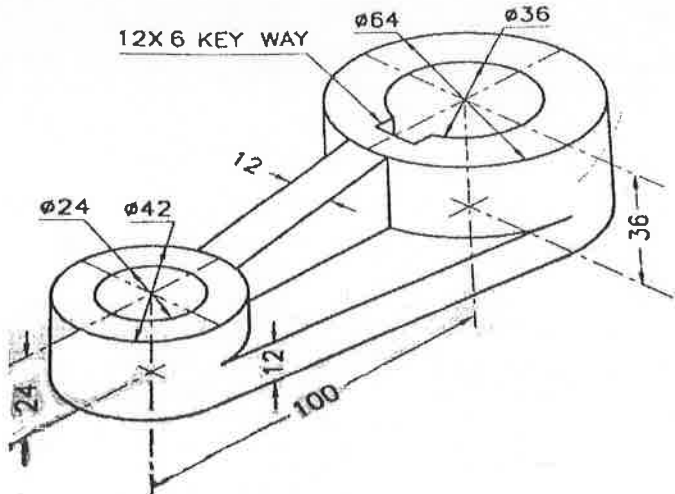
III.	<p>The isometric view of an object is shown in figure 1, draw front view and top view.</p>  <p align="center">Figure 1</p>	M3.01	U
IV.	<p align="center">OR</p> <p>Draw sectional front view and top view of an object shown in figure 2.</p>  <p align="center">Figure 2</p>	M1.02	U

V. Draw the isometric view of a model, whose two views are shown in figure3.

M4.03

A

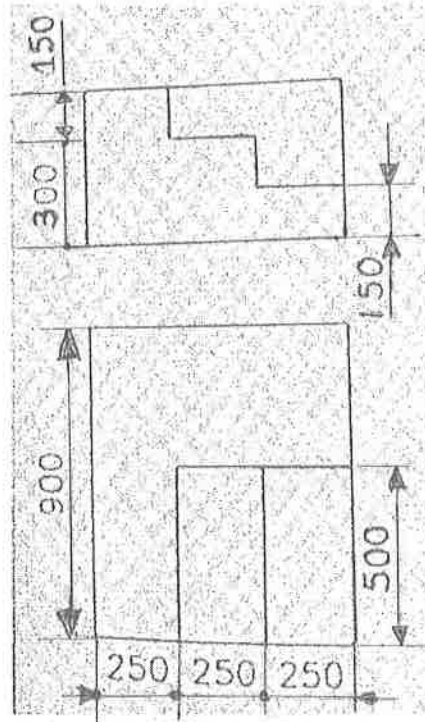

Figure 3
